



EDAMA
Energy, Water & Environment

**The Value Of Energy Storage In Jordan
Opportunities & Challenges.**



European Union

EU-Jordan Green Energy partnership





The state of energy in Europe

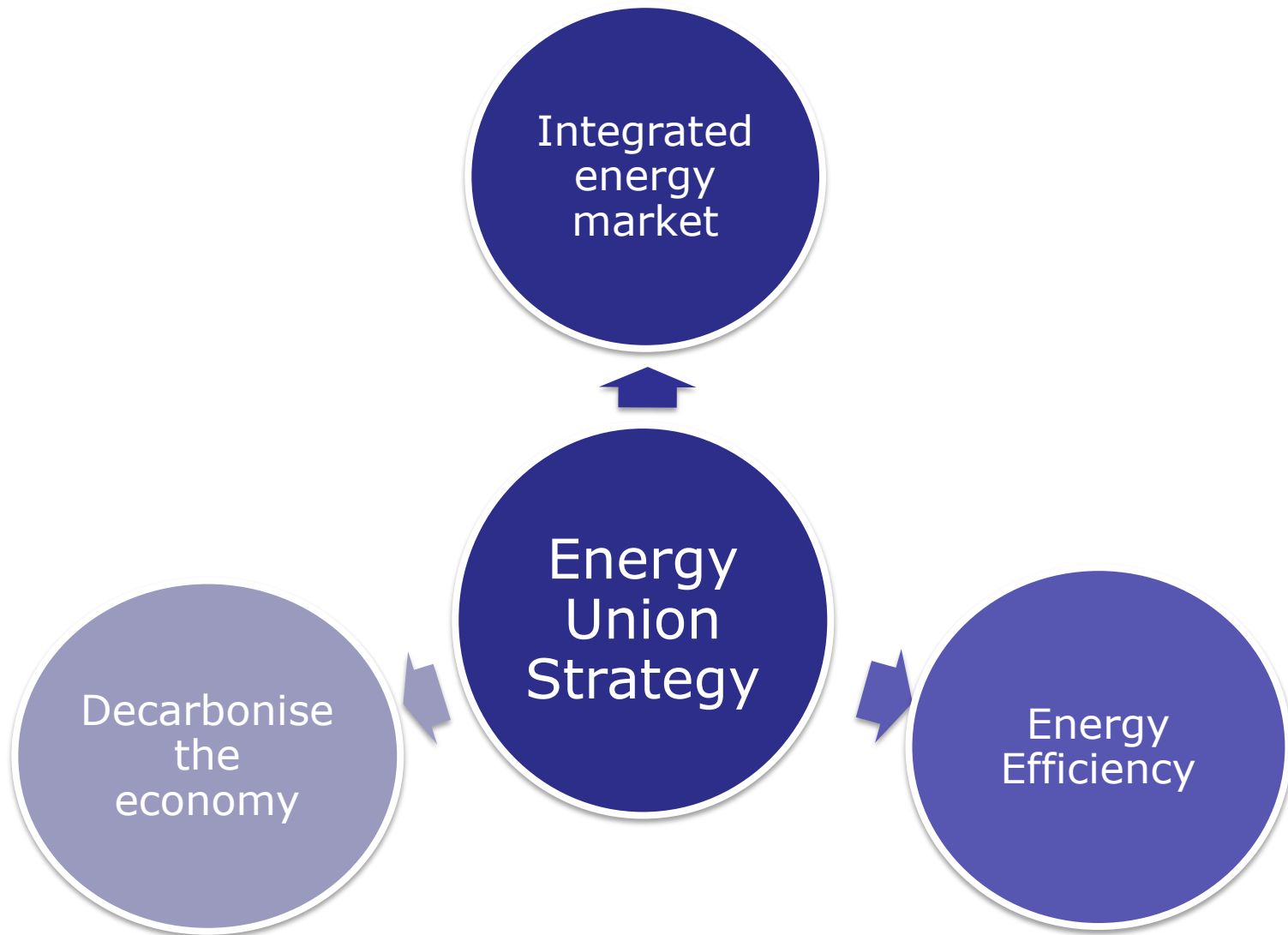



European Union

The State of Energy in Jordan

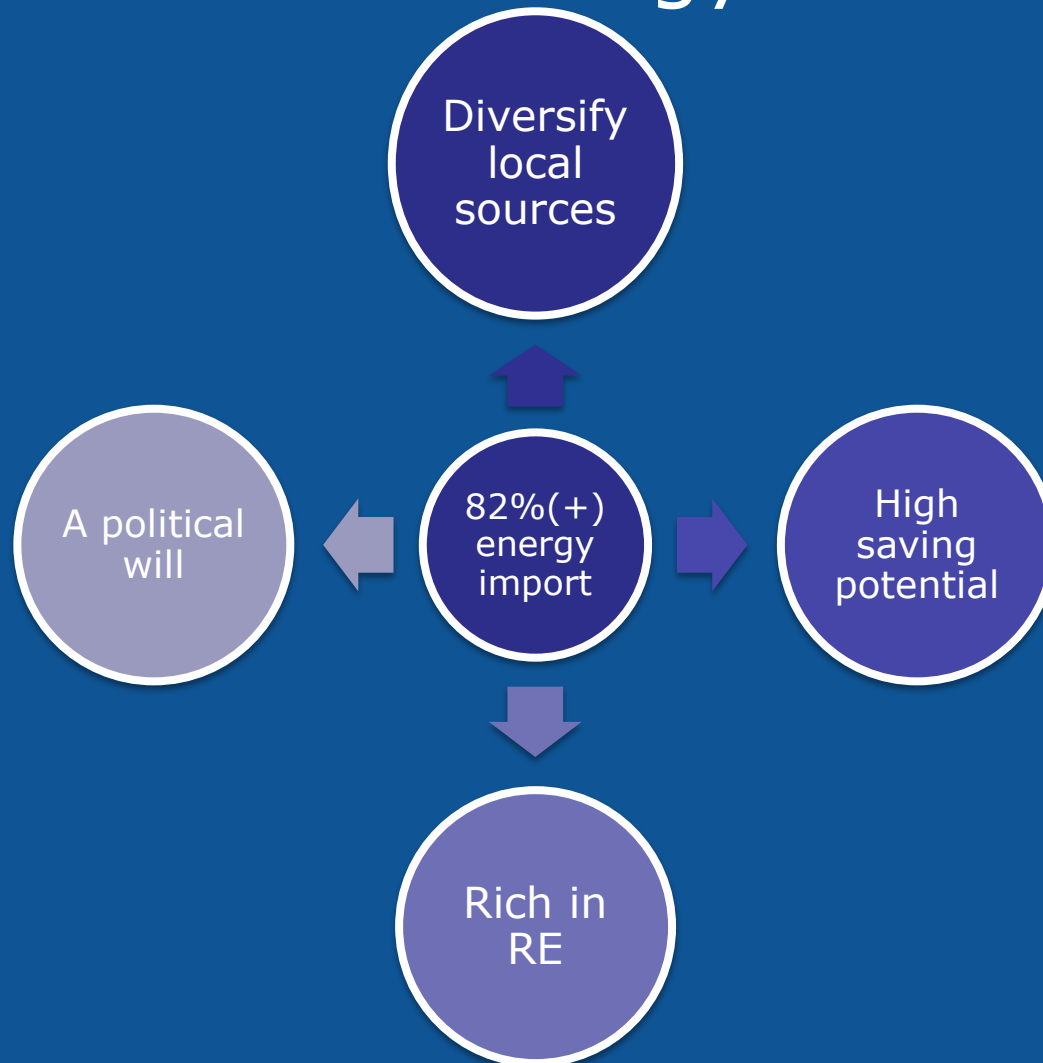



EU vision





European Union

EU – Jordan energy partnership



A long
standing
partnership

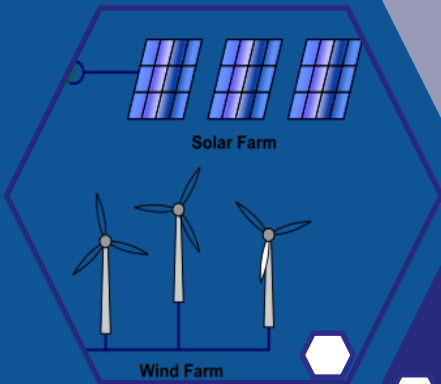

More
cooperation
on green
sources of
energy

Nuclear
Safety
Cooperation





Main interventions:

Bilateral support:

- 1st twinning for the energy sector with NERC on wind and solar energy (2008)
- Wind Energy and Concentrated solar power project WESCP (2010)
- 2nd twinning for the energy sector with NEPCO for RE integration into the grid (2013)
- Technical study for the Green Corridor with EIB for the benefit of NEPCO (2014)
- 1st sector budget support: Renewable energy and energy efficiency programme REEE I (2012)
- 2nd sector budget support: Renewable energy and energy efficiency programme REEE II (2016)
- Green Corridor project with EIB for the benefit of NEPCO (2017)



Main interventions:

Regional support:

- Union for the Mediterranean energy platforms and groups UFM
- Mediterranean Energy Market Integration Project MED-EMIP
- Mediterranean Energy Efficiency Cooperation Programme MED-ENEC
- Mediterranean Regulatory Cooperation MED-REG
- Mediterranean Energy Operators Cooperation MED-ENER
- Sustainable Urban Demonstration Energy projects SUDEP
- Cleaner Energy Saving Mediterranean Cities CES-MED
- Climate – Energy Mediterranean project CLIMA-MED



Lessons learnt from EU support to Jordan:

- EU considered as a development partner
- EU targeted main green sectors via the energy support: water, transport, environment, waste management, agriculture, local development, buildings, research ... etc.
- EU needs to complement institutional and TA with further greening themes and innovation (notably the E-W-F NEXUS approach, RE storage, e-mobility, efficient use of resources) and finance opportunities
- EU can help convert development and climate challenges to green economic growth opportunities
- EU to continue mainstreaming greening themes in education, vocational training and awareness



EU opportunities:

- Global Climate Leader
- Green Deal
- Circular Economy/SCP
- Sustainable mobility
- NEXUS model
- Covenant of Mayors

Simply Green Growth and Economy



**However, Europe will not
achieve the Green Deal
alone, and foresees to offer
its technical and financial,
experience to its partners**

Leaving No One Behind



The main elements of the green deal are as follows:

- Increasing the EU's climate ambition
- Clean, affordable energy
- Mobilise industry to circular economy
- EE in new and renovated buildings
- A zero pollution ambition
- Preserve and restore ecosystems and biodiversity
- The "Farm to Fork" approach as environment friendly food system
- Shift to sustainable and smart mobility



Thank you for your
attention!





The Value of Energy Storage in Jordan - Opportunities & Challenges

EDAMA Workshop, 30 June 2020



European Bank
for Reconstruction and Development

Global trends in distributed vs centralized generation

Annual DER Vs. Annual Central Generation Capacity Additions (MW), World Markets: 2020-2030

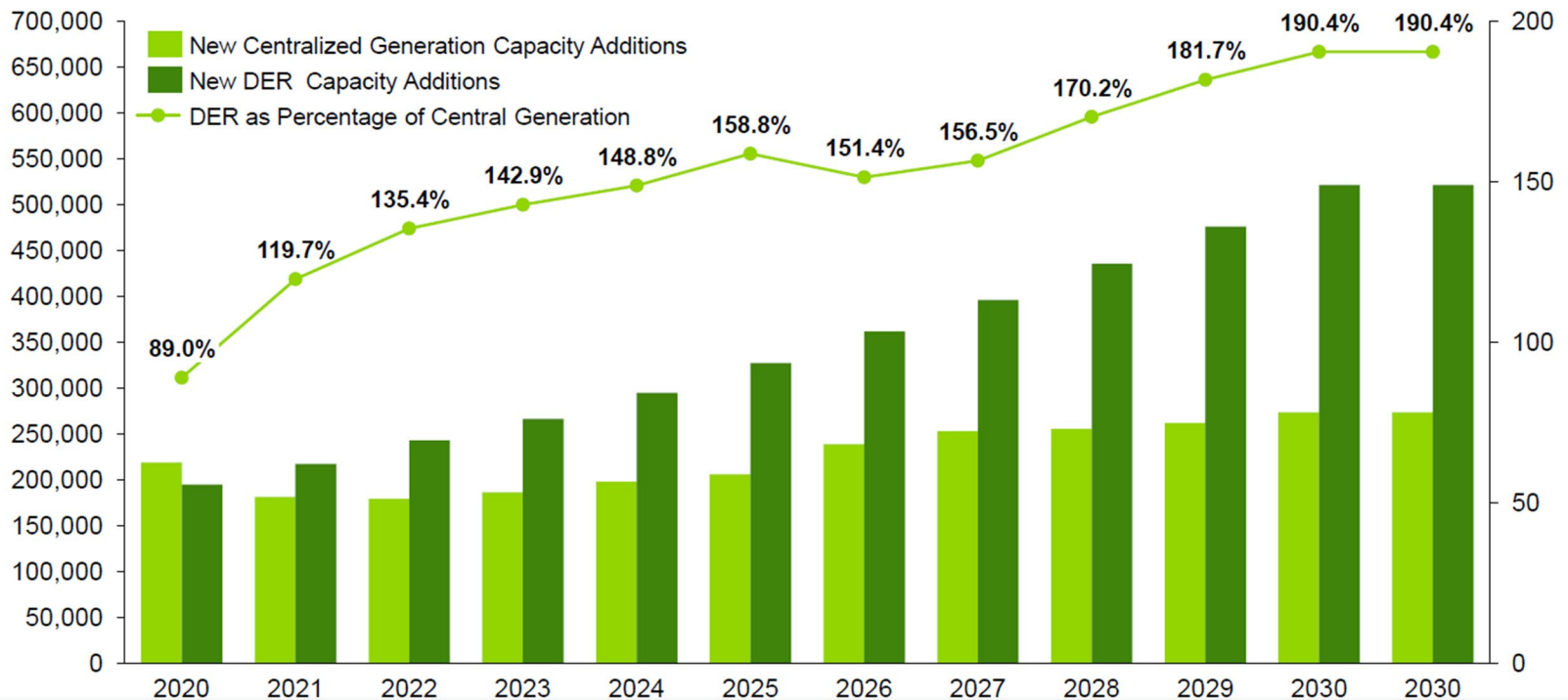

Navigant presentation, 2020

Setting the scene – the context of Jordan



High VRES shares in the energy mix is driving the need for flexibility

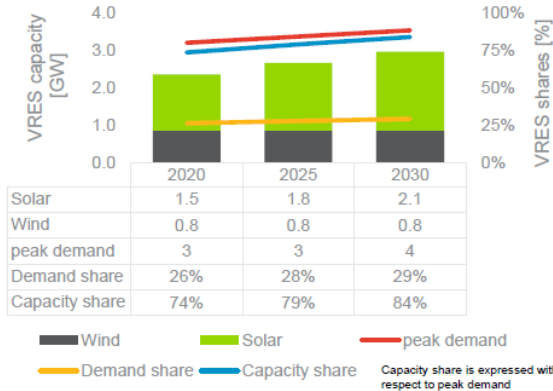

- 2.3 GW of VRES are currently installed covering 35% of the capacity mix.

Flexibility players will need to negotiate a contract with the TSO or target BTM end users

Market segments	Market prices ¹
Single buyer market	US \$ ct/kWh
Generation + T&D cost ²	fuel cost ³ + 6
Balancing cost	N/A
Reserve cost	N/A
Industries ⁴	22.3
Commercial	26.3
Residential (subsidized 80%)	5 – 36

- Jordan operates under a single buyer power market, limiting potential stacking of revenues.
- Prices for end-users are very high and a ban is imposed for wheeled solar projects > 1 MW.

Flexibility options are rather limited given the generation mix and regulatory framework

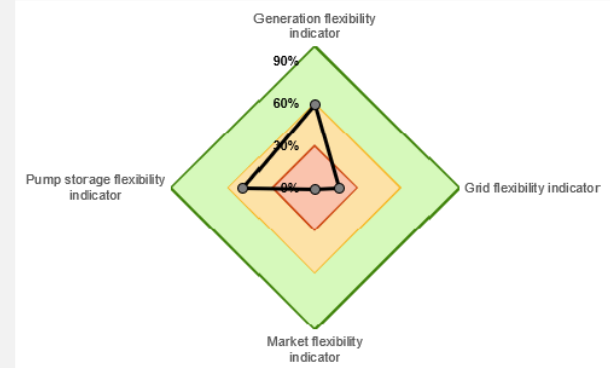

- Majority of power plants are highly flexible and Jordan plans to install 300 MW of pump storage.
- Without a proper market design framework, Jordan underutilizes its cross border capacity.



Peak load

3.2 GW



Demand growth

<1%



Reserve margins

30%

¹ Market prices are taken from NEPCO statistics 2018. A more detailed outlook can be found [here](#).

² GT&D cost are taken from EMRC statistics 2017. A more detailed outlook can be found [here](#).

³ Fuel in 2017 amounted to 8ct/kWh

⁴ Industries connected at the MV level are exposed to time of use tariffs and peak load charges, which are favorable incentives for BTM (behind the meter) batteries.

EBRD support to growth of RE in Jordan

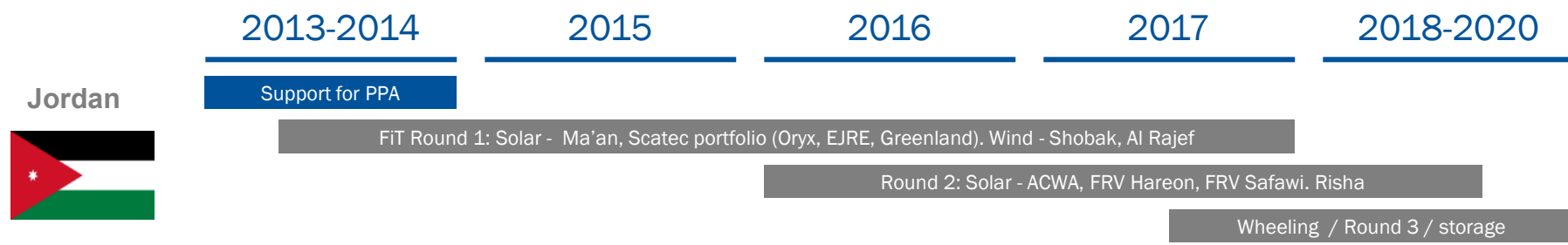

- Policy Dialogue**
 - Regulatory gap analysis
 - Roadmap
 - Assistance to support critical policy changes
- Project Preparation Support**
 - Apply and spread best practices
 - Achieve cost saving from synergies across similar projects
 - Encourage investment by reducing financial costs
- Investment**
 - Private to Private projects (Wheeling)
 - Direct Proposals projects
 - Leveraged by up to 10% concessional financing



EBRD Technical Cooperation project with EMRC

The assignment is part of an international donor-led initiative, in partnership with the Ministry of Energy and Mineral Resources (MEMR) and Energy and Minerals Regulatory Commission (EMRC)

The key objectives of the assignment were to:

1. Assess the suitability of the current regulatory framework
2. Peer review and recommendations to amend the framework
3. Assess the licensing process
4. Propose model licence documents
5. Draft technology neutral project agreements



Battery tender in Jordan

Key risks identified for lenders

1. **Duration mismatch** between SLA of 15 years and battery life
2. **Tariff:** Fixed Payment will be used to service debt. But could be in conflict with the Variable Payment may be paid faster
3. **Regulatory uncertainty:** energy storage not covered in laws on electricity

- Some suppliers offer (a) 15-year battery warranty; or (b) lease payment with Capacity Maintenance Agreement
- Lenders can (i) insure EPC contract cover some cost of degradation (but will not take the battery cost risk), (ii) Maintenance Reserve Account contributed by proceeds of Variable Payment
- Lenders will stress the model at up to 2 full cycles/day, which will reduce the battery life but will be compensated by a higher Variable Payment
- EBRD technical assistance helping to amend the law



How EBRD can help?

Long tenor

which fits the projects' contractual arrangements

Limited recourse financing

attractive for foreign/private investors

Competitive margins

putting downward pressures on energy cost, further promoting renewable energy projects

High leverage

to accelerate the deployment of renewable energy projects.

Currency

ability to lend in both USD and JOD

Concessionality

Implementing institution for a number of grant and concessional fund providers

Technical Cooperation

Funds for project preparation, capacity building, and training



EU NEIGHBOURS
south

NAMA Facility

Thank you for your attention



European Bank
for Reconstruction and Development

Ghaith Assamak

Associate Banker

Energy EMEA

Tel: + 962 6 563 50 59

Email: assamakg@ebrd.com

www.ebrd.com





CLEANHORIZON

The Energy Storage Experts



The Value of Energy Storage in Jordan - Opportunities & Challenges

Naim El Chami

June 30th 2020

Contact:

nec@cleanhorizon.com

Office (FR): +33 (0)1 78 76 57 04

Cell (FR): +33 (0)6 51 70 51 13



Clean Horizon: *the energy storage experts*

Since its creation in 2009, Clean Horizon has been a consultancy 100% dedicated to energy storage

Our core activities

Market analysis



- Off the shelf reports
- Update from the Field subscription
- CHESS database
- Customized analyses

Technical consulting



- Energy storage project sizing and owner's engineering
- Due diligence
- Grid impact studies

Find out more about Clean Horizon



www.cleanhorizon.com



www.linkedin.com/company/clean-horizon/



[@CleanHorizon](https://twitter.com/CleanHorizon)

> 150



engagements

20



different countries

> 390
MWh



ESS designed

2



international offices

> 1000



projects monitored in CHESS



Agenda



1. Introduction to global energy storage markets



2. The role of energy storage in the transition to renewable energy



3. Energy storage needs and trends in the MENA region





Training session - agenda

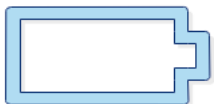

1. Introduction to global energy storage markets

Existing energy storage technologies

Current state of the energy storage market

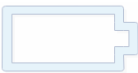

The different energy storage technologies

There are several methods to store electricity, below the categories of energy storage and the common technologies* associated within these categories

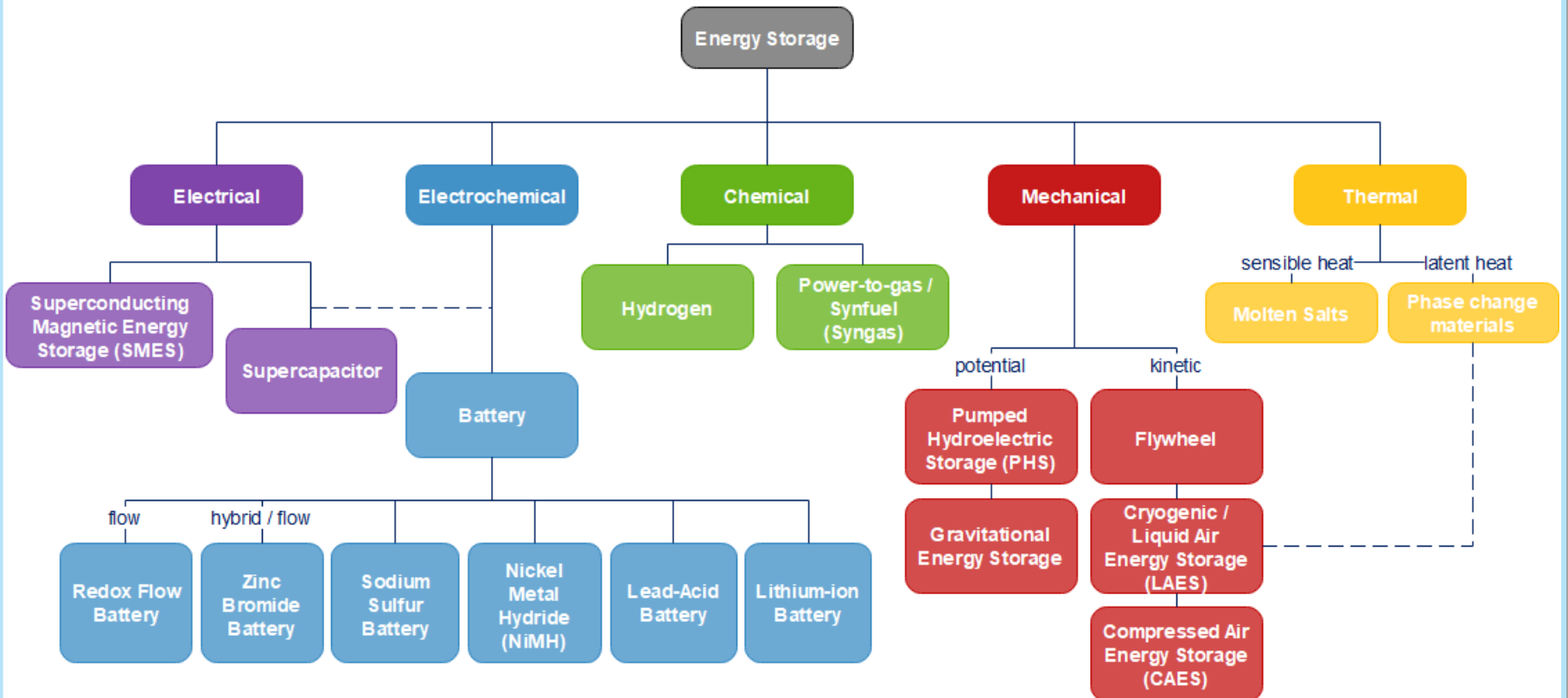

Each type of technology has specific characteristics which may render it more appropriate for certain applications and/or certain geographies and environments

Dotted lines suggest ambiguity of category (can be considered both) or employing waste heat for increased efficiencies

*Non-exhaustive list of technologies



Global Large-Scale Energy Storage Project Announcements (~120 GW of pumped-hydro excluded)

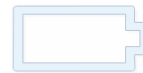

Announcements of Large-Scale Energy Storage Projects

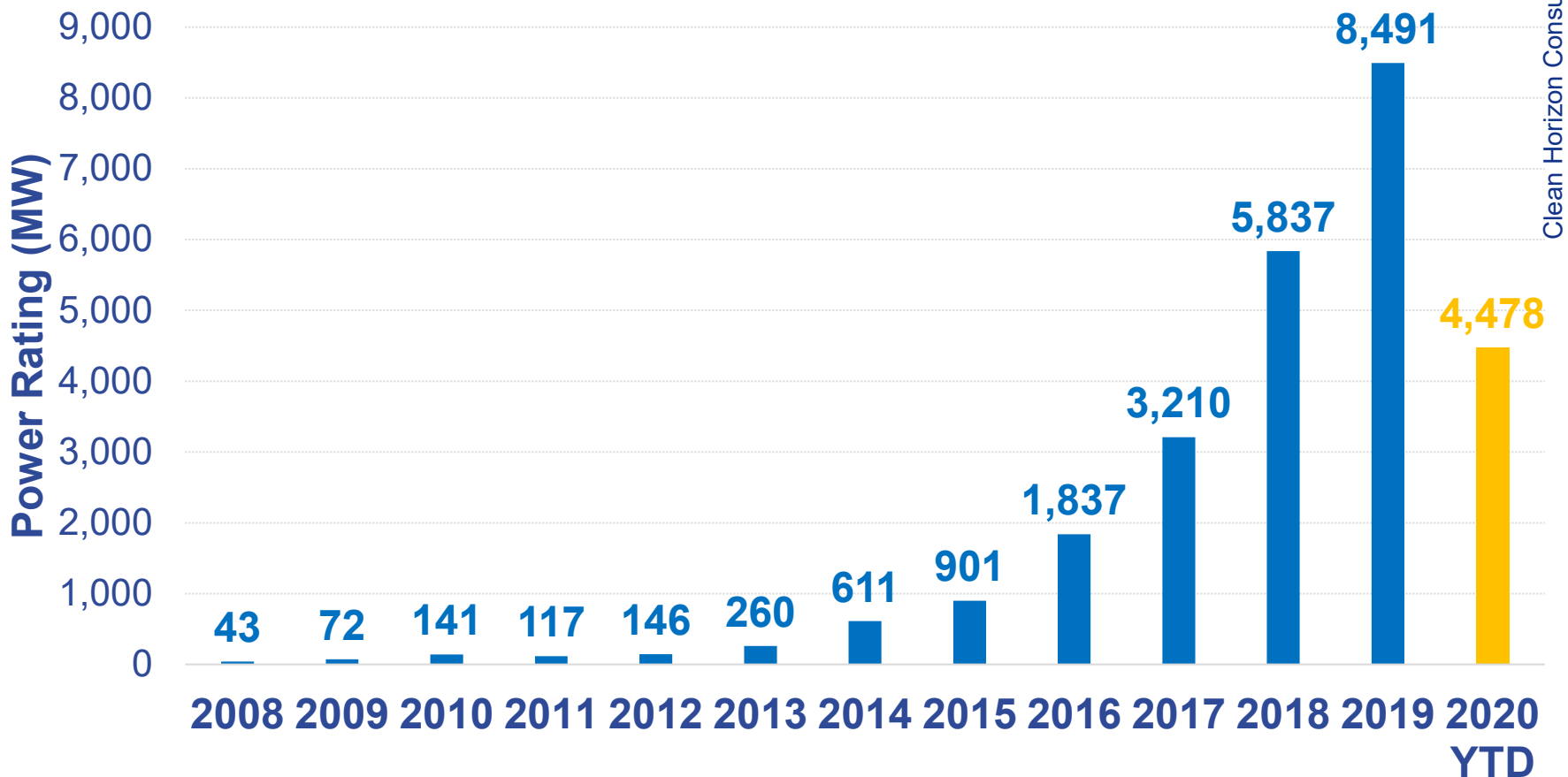

Finally, energy storage is growing exponentially!



Source: Clean Horizon Energy Storage Source (CHESS) - June 2020

* These values exclude the 7.5GW/30GWh Sun Cable Tennant Creek facility (Northern Territory, Australia)



Current state of the market: Global Overview – large-scale energy storage installations

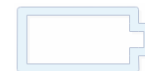

Global Large-scale Energy Storage Projects by Status (as of June 2020)

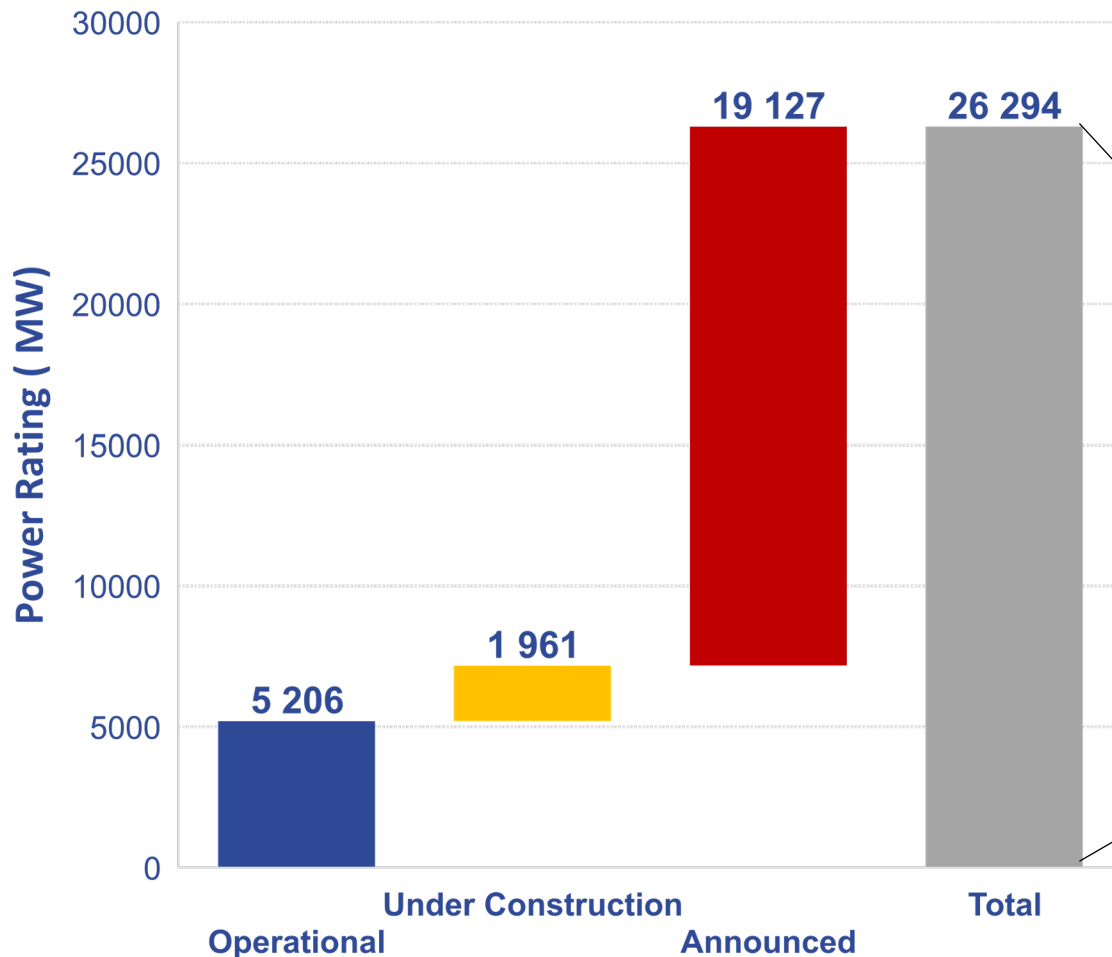

At the global level: 23 GW of battery storage projects, with roughly 80% under development and almost 85% lithium-ion batteries

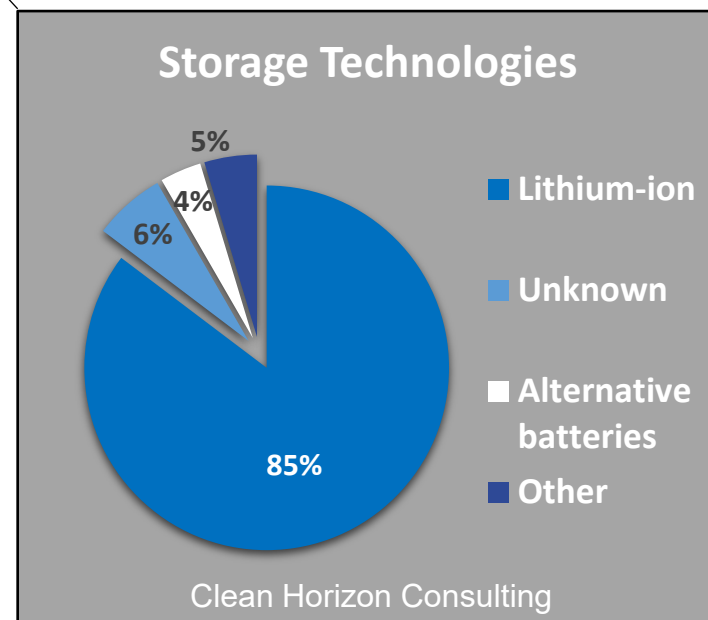

Source: Clean Horizon Energy Storage Source (CHESS) - June 2020

* These values exclude the 7.5GW/30GWh Sun Cable Tennant Creek facility (Northern Territory, Australia)



Agenda



1. Introduction to global energy storage markets



2. The role of energy storage in the transition to renewable energy



3. Energy storage needs and trends in the MENA region





Battery-based energy storage is entirely scalable and can theoretically be installed at any location on the grid

Storage can deliver multiple applications at different grid levels

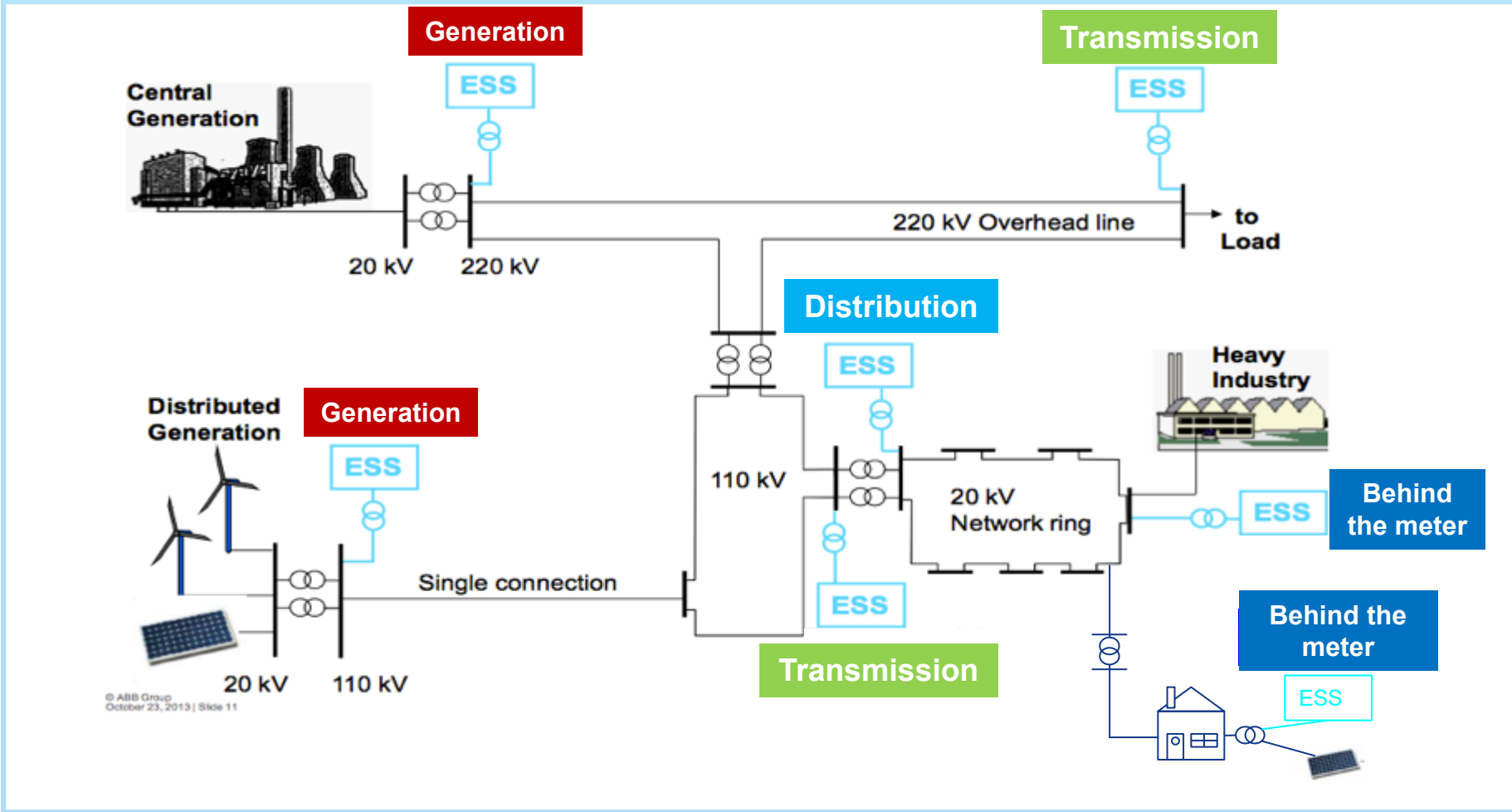



Possible applications of grid-connected battery storage systems



Possible point of connection

Application	Possible point of connection		
	Generation	Transmission and Distribution	Behind the meter
Frequency regulation	★	★	★
Renewables plus storage	★		
Capacity	★	★	★
Energy arbitrage	★	★	★
Voltage regulation	★	★	★
Grid congestion avoidance	★	★	★
PV self-consumption			★
Electricity bill reduction			★



Agenda



1. Introduction to global energy storage markets



2. The role of energy storage in the transition to renewable energy

- **Ensuring grid stability**
- Optimizing the usage of conventional generation
- Providing load shifting services



3. Energy storage needs and trends in the MENA region





Frequency regulation

This service aims at ensuring the balance between generation and consumption



The frequency is the image of a power imbalance on the network

Grid Frequency (Hz)



Control Reserve (MW)

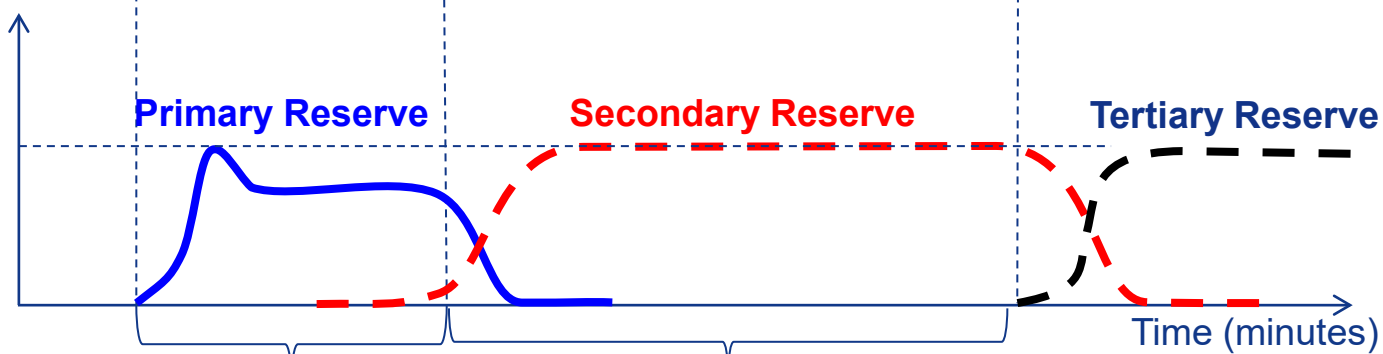

Stop the frequency drift Resolve the frequency drift

- Batteries are well suited to provide primary reserve due to their fast response
- Assets get remunerated by the grid operator for each MW available to provide the service



Integrating renewables creates (invisible) issues which can be solved by storage



Storage restores an acceptable system response

As storage reacts faster than conventional generators, the frequency is restored more quickly

Frequency evolution of a 20 MW microgrid supplied by thermal generators and PV, following the tripping of a generator, in presence of energy storage

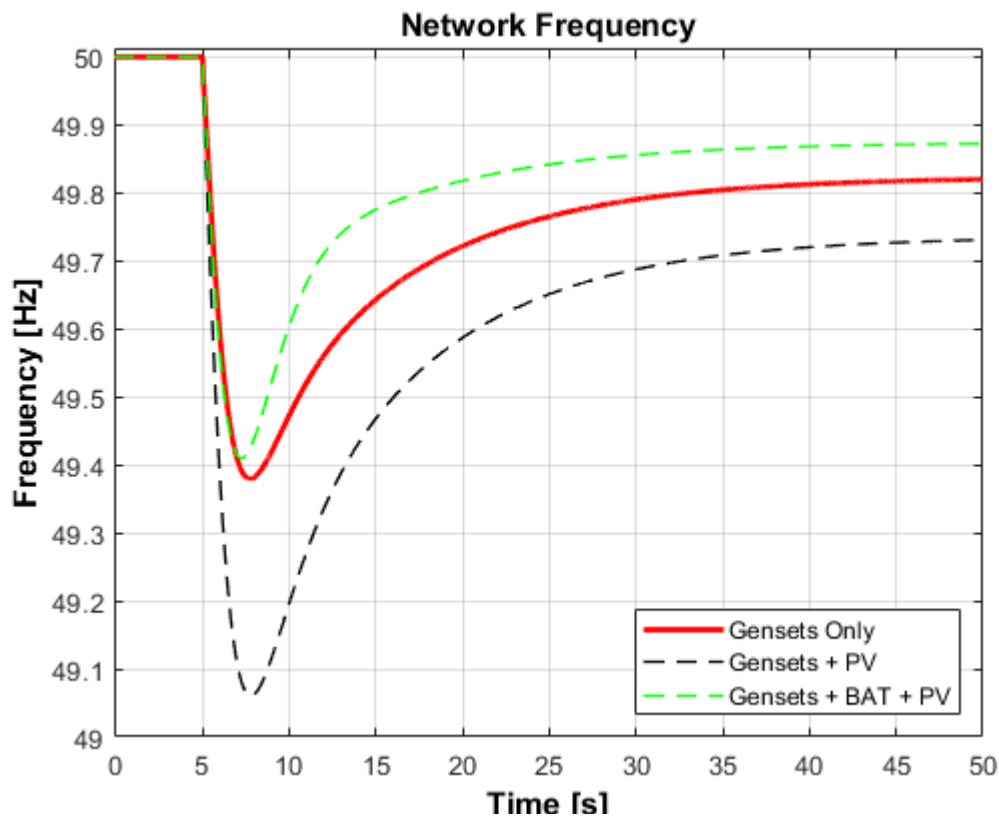

The fast-acting capability of (battery) storage helps stabilize networks with high levels of renewable penetration

Several grid operators have implemented (or are implementing) storage for this purpose:

- UK (200 MW)
- South Australia (70 MW)
- Mauritius (18 MW)
- France (ZNI) (23 MW)
- Hawaii (25 MW)
- Jamaica (18 MW)
- Bermudas (10 MW)
- Barbados (5 MW)



Agenda



1. Introduction to global energy storage markets



2. **The role of energy storage in the transition to renewable energy**

- Ensuring grid stability
- **Optimizing the usage of conventional generation**
- Providing load shifting services



3. Energy storage needs and trends in the MENA region





Storage can optimize the way conventional generation is used



Example of a sub-Saharan country

WITHOUT STORAGE

Reserve provided by cheapest power plant... Which must be kept turned on even during hours of high PV generation

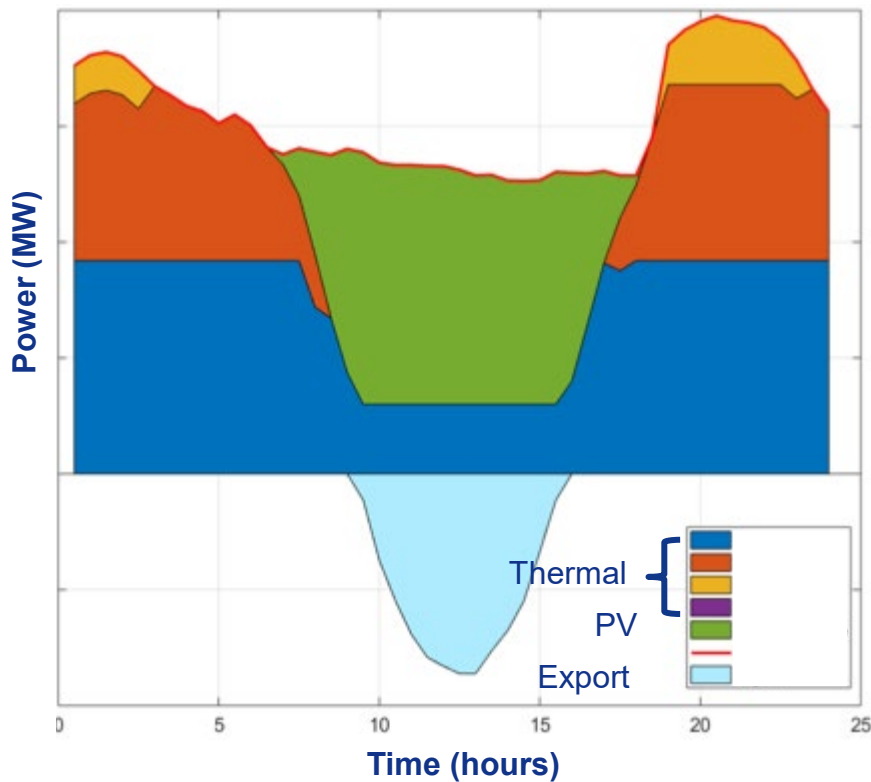

WITH STORAGE

Cheapest power plant is turned off during PV hours thus allowing more PV consumption AND can be turned on fully during the rest of the day

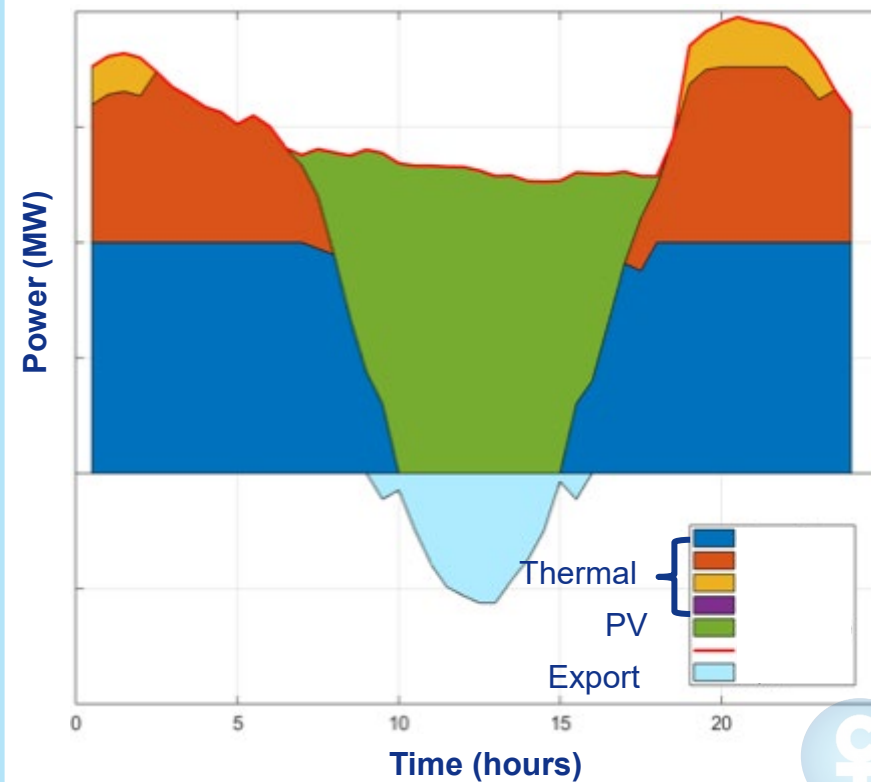



Agenda



1. Introduction to global energy storage markets



2. The role of energy storage in the transition to renewable energy

- Ensuring grid stability
- Optimizing the usage of conventional generation
- **Providing load shifting services**



3. Energy storage needs and trends in the MENA region





In theory, storage can provide load shifting services, but this application remains rare in the current market conditions



Insufficient capacity leads to load shedding and usage of expensive peakers at the evening peak

Dispatch of the various energy sources over one day, without storage

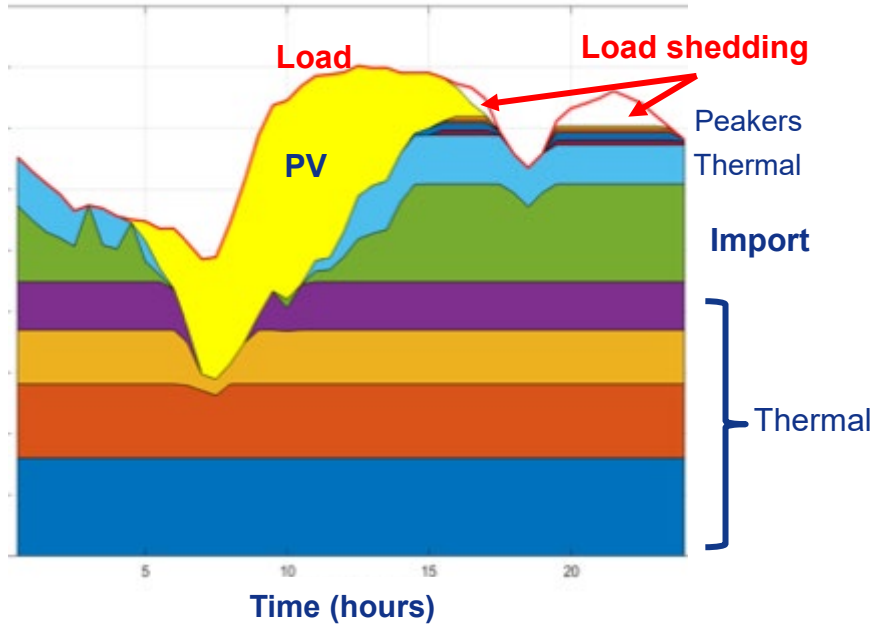

Storage can effectively shift PV to the evening, thus reducing load shedding and peaker usage

Dispatch of the various energy sources over one day, with storage

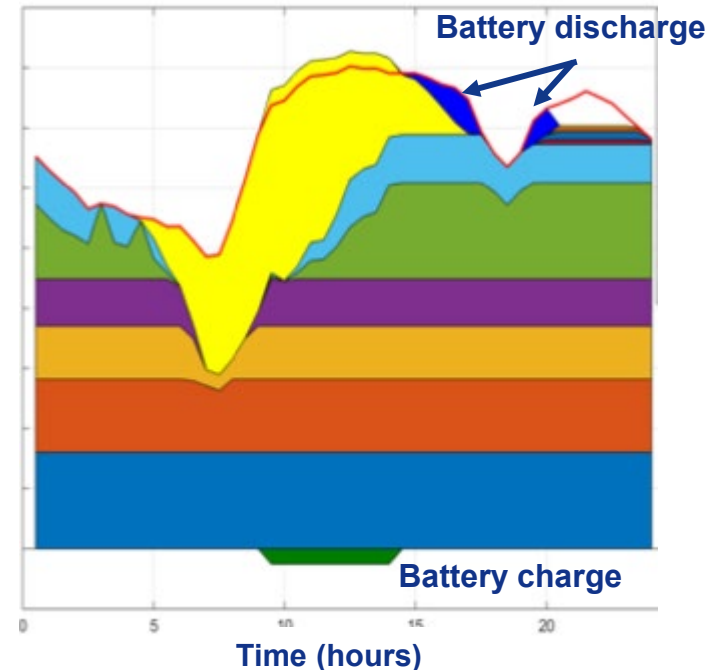



Renewables plus storage -

Energy issued from PV-plus-storage is becoming competitive with all forms of conventional generation



Cost of PV plus storage have decreased from over 300 \$/MWh to less than 50 \$/MWh

Project revenues

(in \$ / MWh)

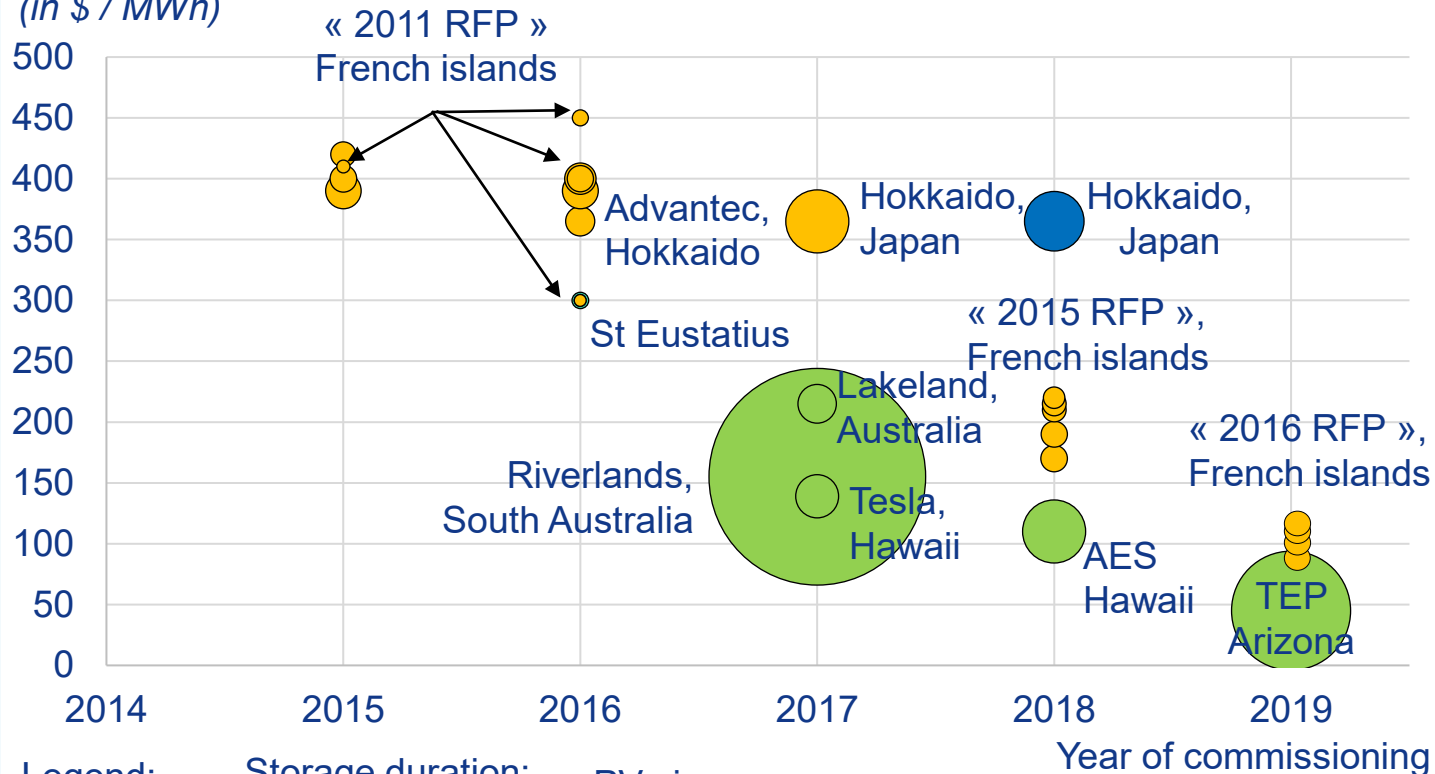

PV and storage can be less expensive than thermal generation

Legend:

Storage duration:

- < 1h
- 1h - 2h
- 2 h +

PV size:

- 100 MWp
- 10 MWp
- 1 MWp



Behind-the-meter application: PV self-consumption

Consumers with rooftop PV can install energy storage to increase the amount of PV energy they use

Example of load shifting for PV generation

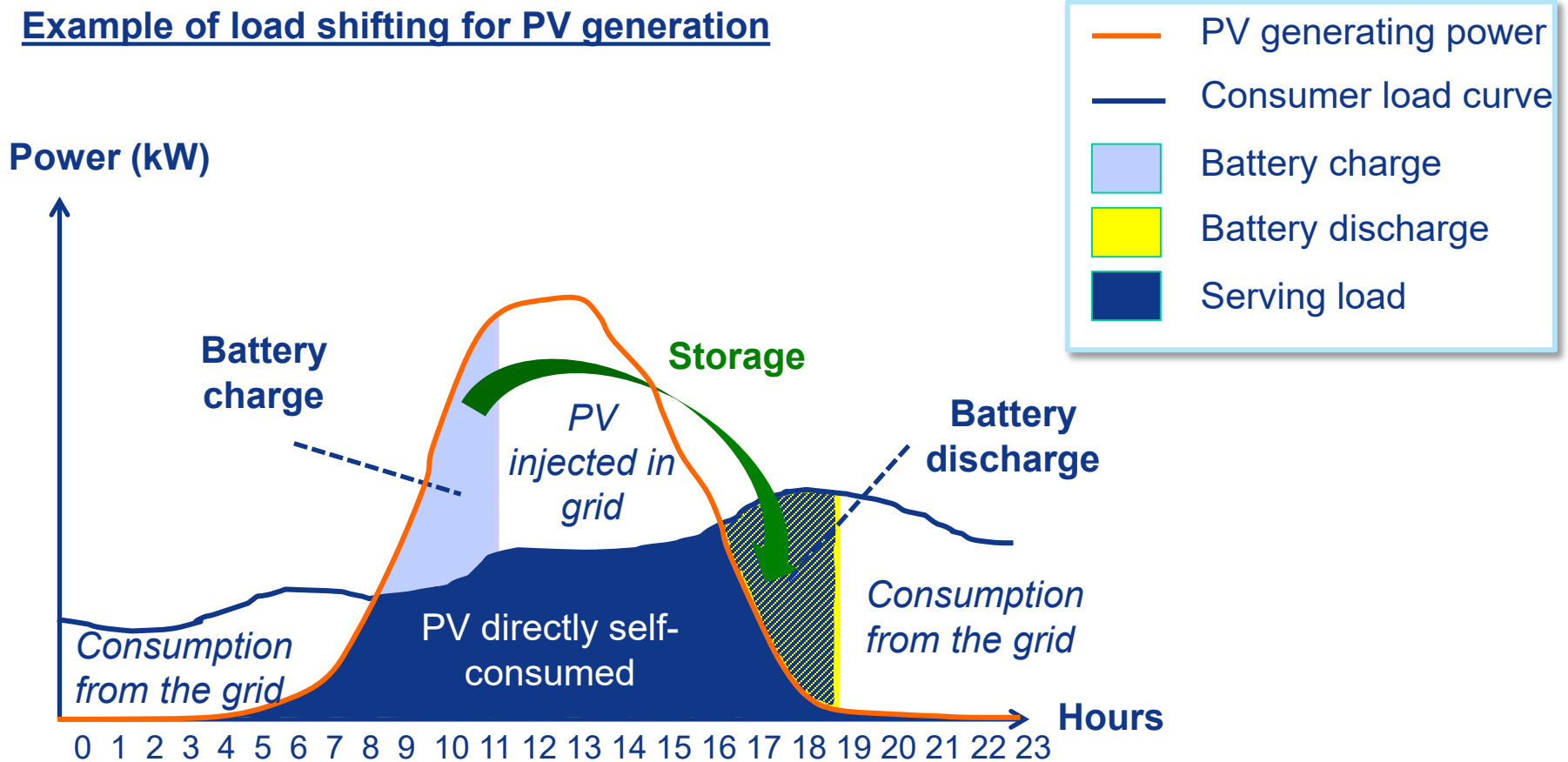



Behind-the-meter application: Energy bill reduction

Consumers can install storage in order to modify their load profile and reduce their electricity bill



Utilities most often bill commercial and industrial customers based on:

- Their electricity consumption through an **energy charge** in €/MWh
- Their peak electricity consumption through a **demand charge** in €/MW

Consumption profile of an industrial site without storage

(MW)

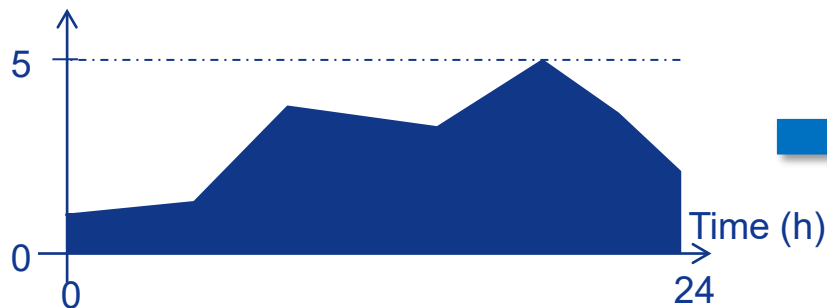

5 MW peak power consumption

Consumption profile of an industrial site with storage

(MW)

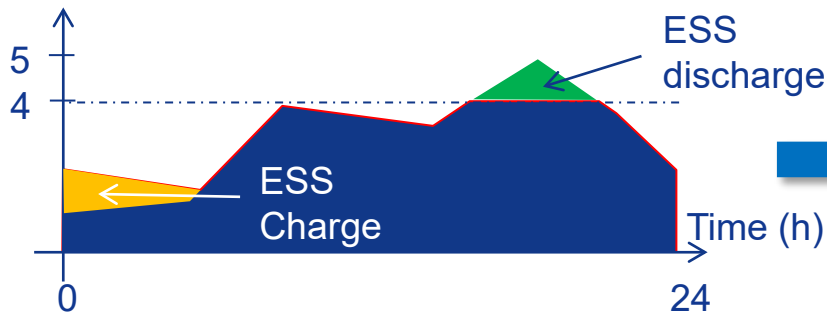

4 MW peak power consumption

An energy storage system allows to reduce the peak consumption

- An energy storage system can reduce the bills of large commercial and industrial customers
- This is done by reducing peak load and hence reducing the demand charge
- This application is common in Ontario (Canada) and in the US (California, NY, Massachusetts)



Agenda



1. Introduction to global energy storage markets



2. The role of energy storage in the transition to renewable energy



3. Energy storage needs and trends in the MENA region





Legend



Concrete opportunity for storage



Partial opportunity for storage



No opportunity for storage



Country overview: Jordan



Nature of the opportunity / rationale for absence of opportunity

When will the opportunity arise?

Discharge duration

Generation	<ul style="list-style-type: none"> PV + storage is being recognized as a legitimate application by the government and two projects exist (one complete, one in bidding phase) High penetration of renewables expected (25% share of renewables by 2020) Market open to IPPs (BOO model) 	Now	Probably 2-3 hours
Grid	<ul style="list-style-type: none"> Ancillary service applications for storage are being studied No regulatory framework for storage 	Most likely in 2021	1 hour
BTM	Flat tiered tariffs and net-metering structurally don't allow storage investment recovery.	N/A	N/A

PHILADELPHIA SOLAR IRBID DISTRICT ELECTRICITY COMPANY PV PLUS STORAGE

The lithium-ion large-scale battery will be the biggest in the Middle East once commissioned this year by Al Badiya (a subsidiary of Philadelphia Solar). A power purchase agreement (20-year PPA with the The Irbid District Electricity Company) was signed for the Middle East's largest solar-plus-storage project to date, 12 MW of PV with a 12 MWh lithium-ion battery, in a project being executed by Jordanian PV manufacturer and EPC Philadelphia Solar.

Location

Island / Mainland:	Mainland
Continent:	Asia
Country:	Jordan
State / Region:	Mafraq Governorate
City:	Mafraq
Connection Point:	Generation

Storage Technology

Technology Category:	Electrochemical
Technology:	Lithium-ion Battery

Status

Status:	Contracted
Annoucement Date:	11/08/2017

Size

Nominal Power (MW):	4.00
Energy Capacity (MWh):	12.00
Duration Discharge (h):	3.00

Revenue(s)

Main revenue:	PV + storage PPA
---------------	------------------

Application(s)

Main application:	Load Shifting
-------------------	---------------

Additional information

Paired Grid Resource:	12 MW PV
-----------------------	----------

Actors

Developer / Owner:	Philadelphia Solar
Off-taker:	Irbid District Electricity Company (IDECO)

References

Hyperlink 1:	Link
Hyperlink 2:	Link
Last Updated:	29/05/2018

Source: *Clean Horizon Energy Storage Source (CHESS)*, Clean Horizon's own global energy storage project database



Country overview: Lebanon



	Nature of the opportunity / rationale for absence of opportunity	When will the opportunity arise?	Discharge duration
Generation	PV plus storage PPAs are the only opportunity for storage today in the country	Now	1 hour
Grid	There is currently no market for ancillary services provision and electricity production relies heavily on fossil fuels	N/A	N/A
BTM	The electricity prices are low and the price structure does not encourage storage adoption. Some minor private initiatives are however emerging.	N/A	N/A



Country overview: United Arab Emirates



Nature of the opportunity / rationale for absence of opportunity

When will the opportunity arise?

Discharge duration

Generation

- Nothing has been done beyond the PV + storage project in Dubai (1.2MW/7.2MWh pilot project)
- Other storage alternatives are being considered (thermal, pumped-hydro, PtG)

N/A

N/A

Grid

- Nothing has been accomplished beyond the already available ADWEA BESS (108MW/648 MWh) but no further intentions
- No current market for ancillary services provision
- No regulatory framework for storage

N/A

N/A

BTM

Flat tiered tariffs and net-metering structurally don't allow storage investment recovery.

N/A

N/A



Country overview: Egypt



	Nature of the opportunity / rationale for absence of opportunity	When will the opportunity arise?	Discharge duration
Generation	<ul style="list-style-type: none">PV + storage is progressively being recognized as a legitimate application by the government.Electricity production relies heavily on fossil fuels	Most likely in 2021	Probably 5-6 hours
Grid	<ul style="list-style-type: none">Recent liberalization of the sectorNo current market for ancillary services provisionNo regulatory framework for storage	N/A	N/A
BTM	Flat tiered tariffs, ToU and net-metering schemes structurally don't allow storage investment recovery.	N/A	N/A



The Middle East, an emerging market with nascent opportunities for energy storage

	Application	When will the opportunity arise?	Discharge duration
Egypt	Renewable integration	Most likely 2021	Up to 6 hours
Jordan	<ul style="list-style-type: none"> Renewable integration Frequency regulation 	<ul style="list-style-type: none"> Now 2020 	<ul style="list-style-type: none"> 3 hours 1 hour
Lebanon	<ul style="list-style-type: none"> Renewable integration Frequency regulation 	<ul style="list-style-type: none"> Now 2021 	1 hour
Oman	Microgrids *	Now	0.5 hours
Saudi Arabia	Renewable integration	2021	2 to 4 hours
UAE	<ul style="list-style-type: none"> Grid congestion management Renewable integration Frequency regulation 	<ul style="list-style-type: none"> N/A 2021 2022 	<ul style="list-style-type: none"> 6 hours Up to 6 hours 1 hour

* Government-owned utility, Tanweer, is developing 11 Solar-Diesel Hybrid sites comprising up to 37 MW of solar PV plus 28 MW of battery storage



Conclusion

- Adoption of energy storage has been witnessing a remarkable growth for the past four years, more recently in the MENA region.
- Applications of storage are mainly related to stability enforcement and reserve provisioning to cope with high renewable penetration
- Other storage technologies could take off, such as flow batteries, hydrogen storage or others, but cost reduction and additional developments are necessary to see these technologies being deployed at a large scale.

What must change to spur energy storage development?

- Bankable PPAs with hourly tariffs allowing to offer tailored projects
- Regulatory frameworks adapted to energy storage and fostering competition

THANK YOU !

nec@cleanhorizon.com
+33 (0)6 51 70 51 13



CLEANHORIZON
The Energy Storage Experts





REEE II

Renewable Energy
and Energy Efficiency II



Funded by
the European Union

Pre-Feasibility Study of Pumped-Storage Hydropower Potential at Mujib Reservoir in Jordan

Progress So Far & Next Steps

Emil Alasis, REEE II TA Team Leader



Introduction to Pumped-Storage Hydropower (PSH)

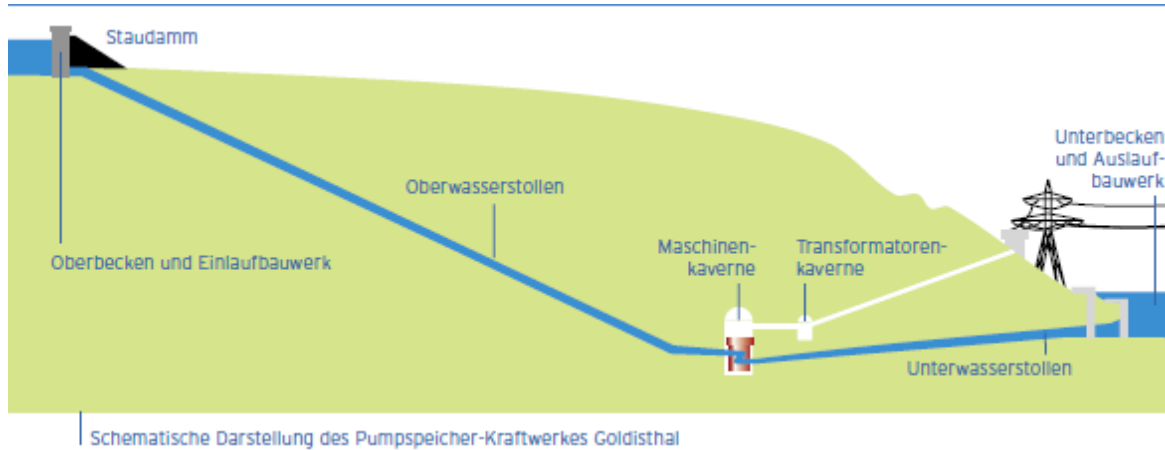

- Storage of large quantities of energy using dualism of hydropower turbines and pumps
- Two reservoirs at different elevations
- Excess energy in grid → pumping
- Energy demand in grid → turbine

Pumped-Storage Hydro at Mujib Reservoir [1]

Technical Findings:

- Mujib Pumped-Storage Plant (PSP) is technically feasible
- Head: around 600 m Discharge: about 40 m³/s
- → Power: about 215 MW Energy: about 1.45 GWh/d
- Underground cavern powerhouse
- Uses volume from old quarry for upper reservoir
- Reversible pump-turbine with motor-generator
- Ramping capability: up to 14.3 MW/s (860 MW/min)
- Can provide extensive grid services and fulfills requirements articulated by NEPCO

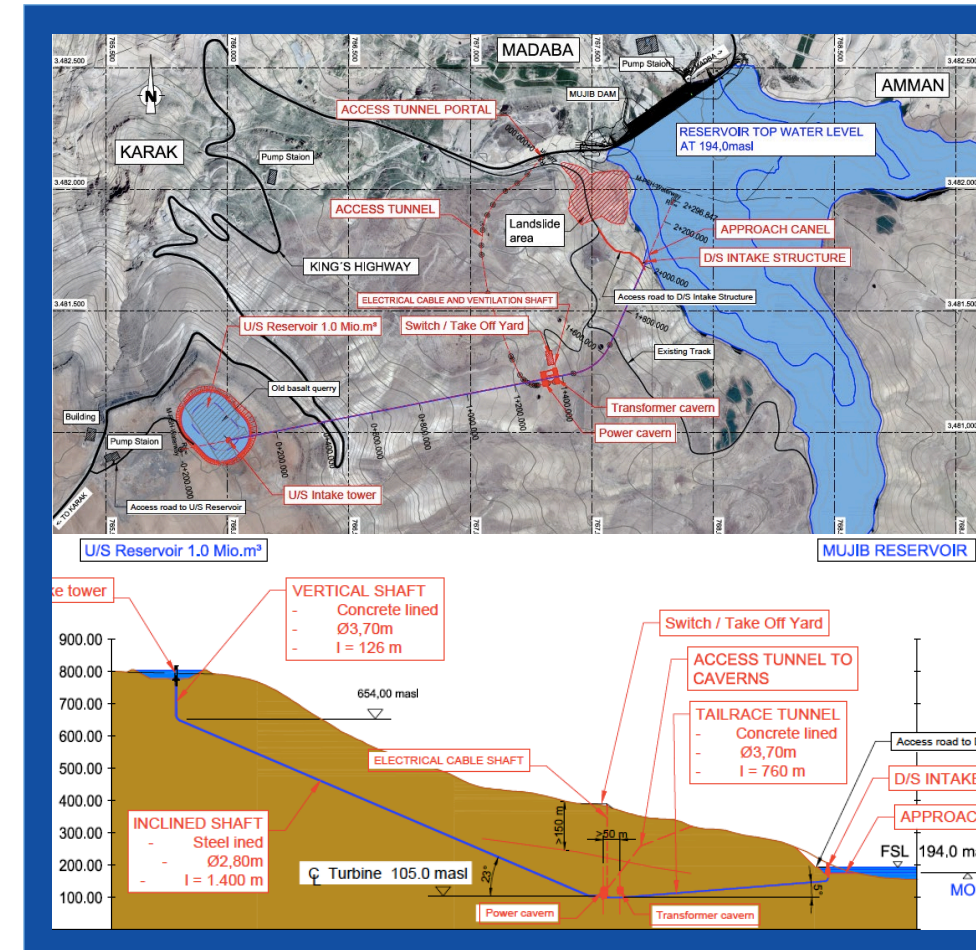

Pumped-Storage Hydro at Mujib Reservoir [2]

Technical Findings:

- Existing reservoir provides sufficient water storage volume today
- In future: sedimentation will reduce life storage volume
→ Problem for pumped-storage but even more so for water supply!
- Potential solution: Incremental increase of reservoir volume using inflatable rubber weir at current spillway crest
- Required height: < 1.0 m
- Compensation of volume for evaporation losses and provision of additional storage for PSP operation

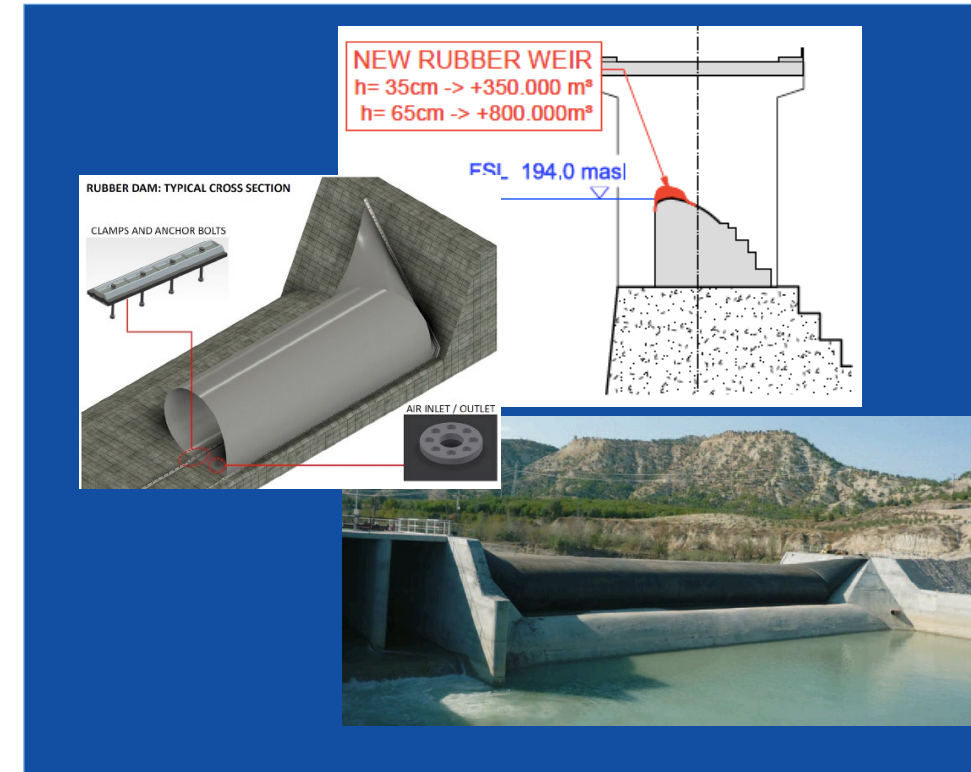

Grid Services expected from Mujib PSH

- Facilitates optimal integration of large-scale variable RE
- Short-, and medium-term energy storage at 82% storage efficiency
- Reduces need to add generating capacity by turning variable capacity from wind and PV into firm capacity
- Reduce environmental emissions
- Reduce cycling and ramping of thermal units
- Grid Stabilization:
 - Primary and secondary frequency control
 - Voltage support
 - Load leveling/energy arbitrage
 - Transmission congestion resolution
 - Black-start capability

Potential PSH Business Models

Public Private Partnership (PPP):

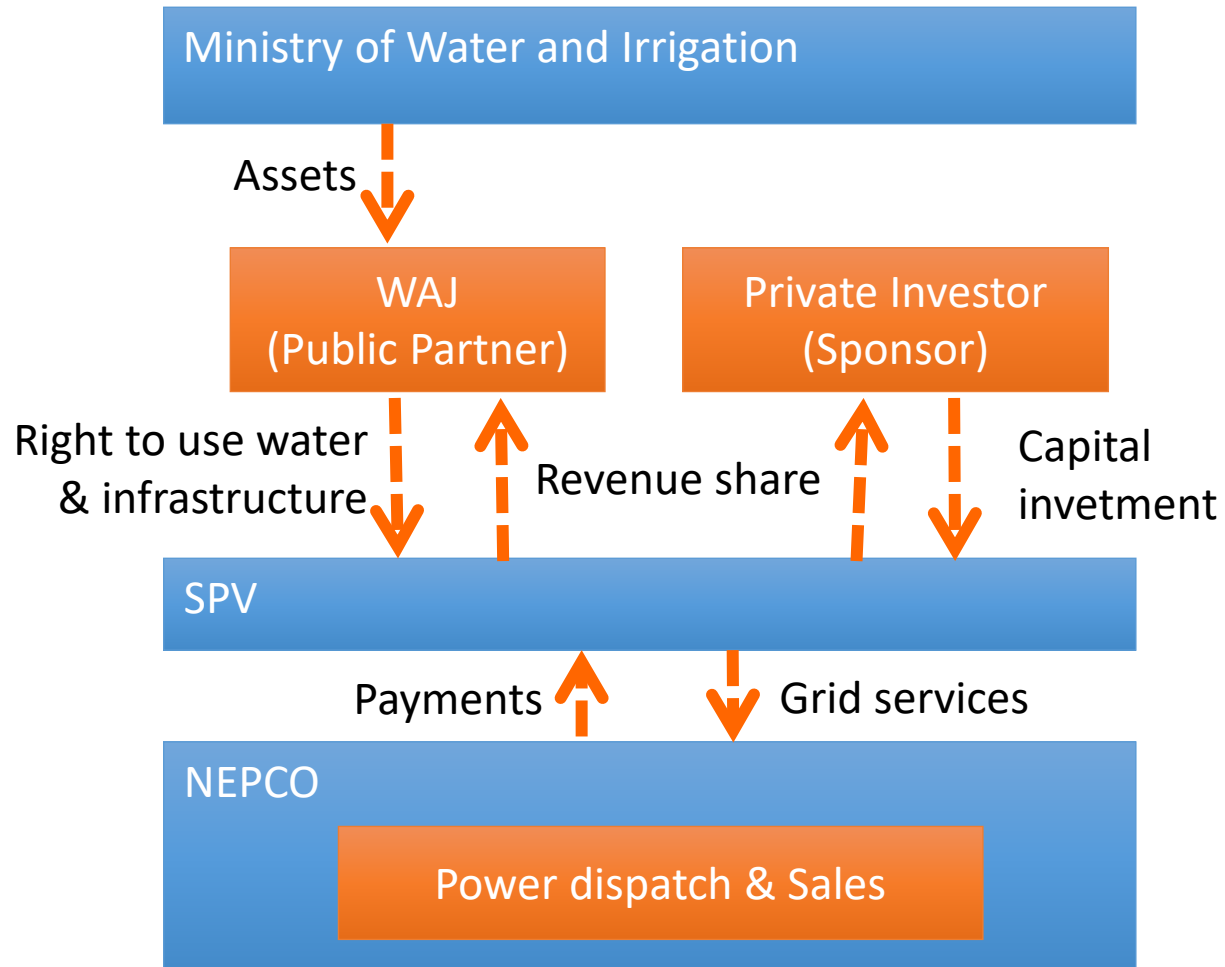

Independent Power "Producer" (IPP):

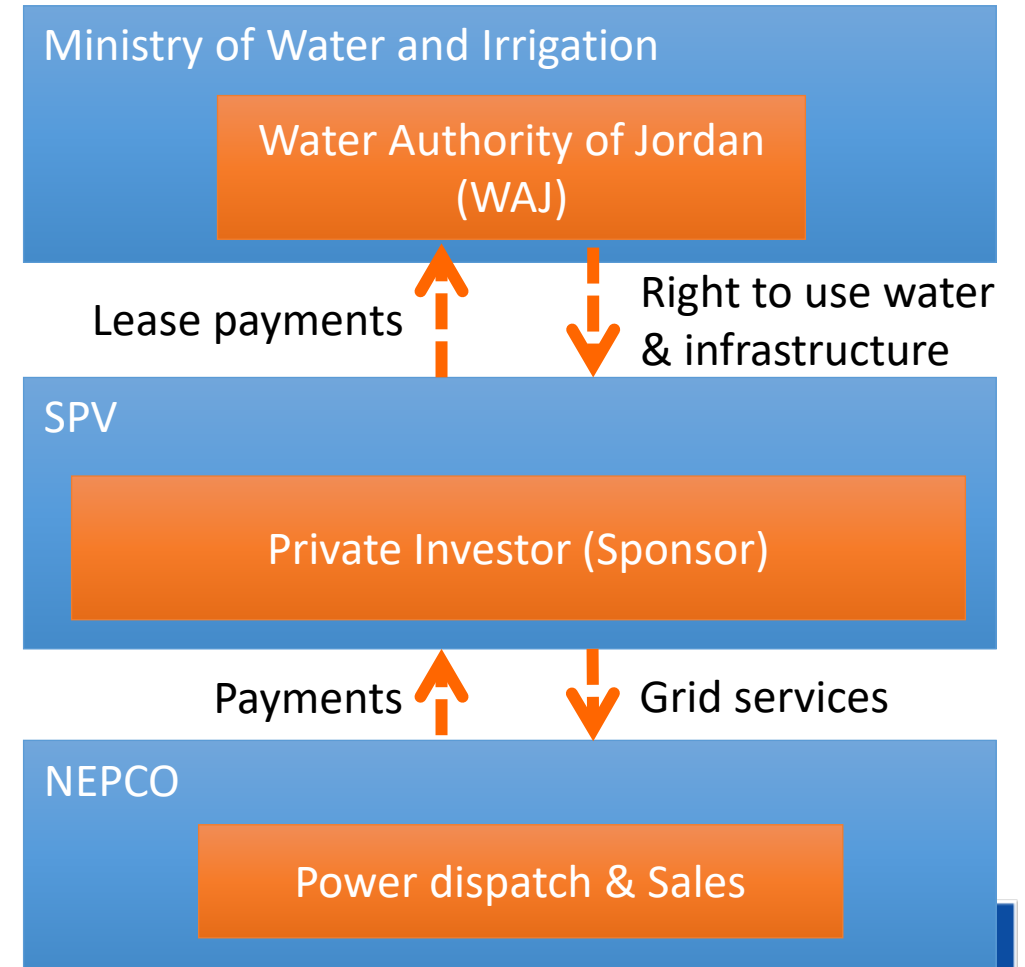

Timeline of Next Steps

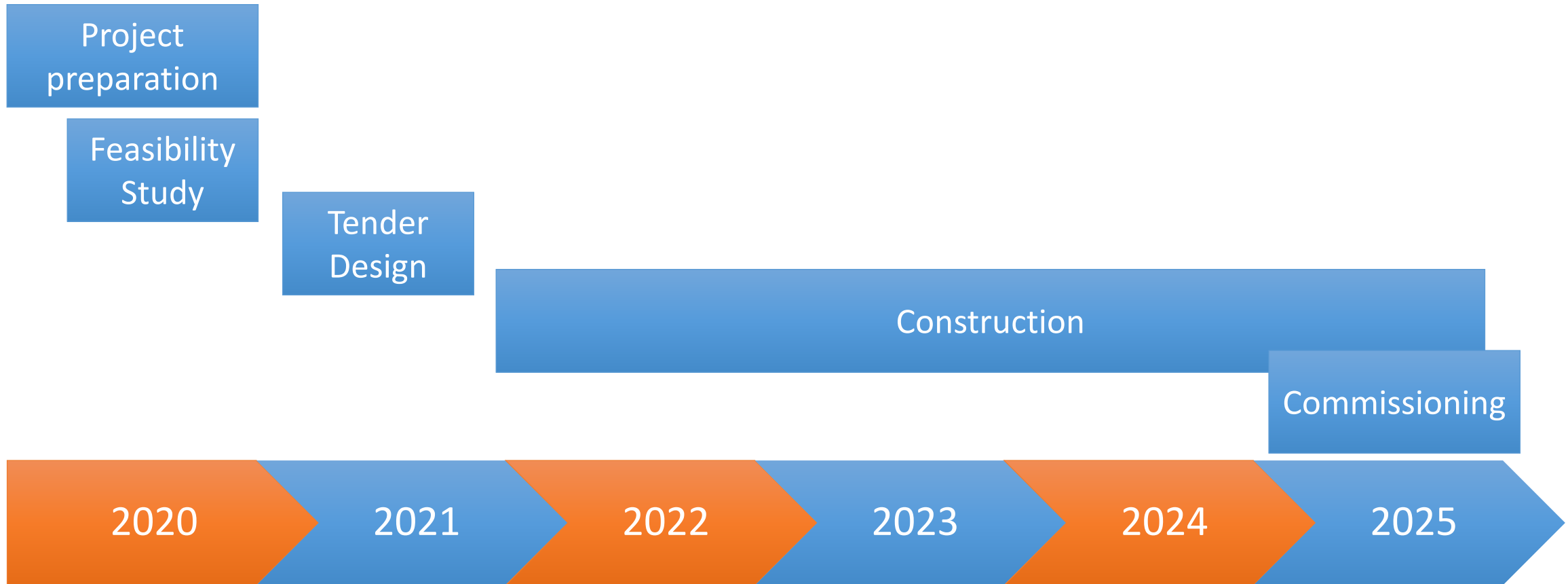

Project Preparation Activities

Recommended Next Steps:

- Power dispatch optimization study
 - Optimize sizing of PSP (MW, MWh/d)
 - Assign role of PSH in national grid (primary/secondary regulation, frequency shifting, load levelling, ...)
- Grid impact study (dynamic simulation) to maximize benefits of PSP
- Geological study
- Optimize technical layout of PSP
- Formulate suggested modifications in regulations to accommodate energy storage services
- Develop concrete business model for PSH
- Conclude inter-governmental agreement for Mujib PSP (ownership, operating, revenue sharing, ...)
- Prepare tender for private involvement in PSP construction and operation

Exchange of Knowledge on PSP

Dialogue with European Pumped Storage Plant Operators

- Implemented business models and project financing (CAPEX & OPEX)
- Regulatory concept and current constraints for PSH
- Operational practice of PSH and grid services provided by PSH
- Networking Opportunities

Site visit to PSH in operation

- First hand knowledge of operational practice

Visit PSH equipment manufacturers

- Technical advancements in PSH technology





Thank you for your attention

